

vEmpire

Whitepaper V2

Created by The vEmpire Team



Foreword

I wrote the original whitepaper over the course of spring & summer 2021. We officially incorporated vEmpire DDAO Ltd on June 21st of the same year and looking back, it's been wild to say the least!

My background was in traditional finance. I started out as a junior stockbroker and I progressed to a senior derivatives trader and head of desk within just two years. After this, I joined St James' Place Wealth Management as an Associate Partner, before moving to a Venture Capital firm where I spent four insightful years before starting vEmpire DDAO.

Both my personal background and my VC firm's speciality was not what you could call "exciting". Instead of investing in glamorous industries, such as blockchain, software and biotech, we typically invested in businesses that were backed by underlying assets. This is known as asset backed investing. Naturally this meant that we invested in a lot of care homes, pubs, restaurants, nurseries and basically any business that had a tangible freehold property that we could take charge of, should the business' underlying trading become unprofitable.

The thought process behind this was that with asset backed investing, you could purchase businesses that had concrete assets, ideally property, which essentially acted as "insurance" as in a worst case scenario, like unprofitability, the asset could cover some of the cost of the initial investment. I believe that it was this experience of focusing on investing in assets that had concrete value that helped kickstart my drive to start the world's first decentralized virtual property management protocol.

"Real world" property vehicles have two measurements of value, price and net asset value. In a normal property fund, when the share price drops below the net asset value, that's when you should be buying. However in the cryptocurrency industry, people don't seem to understand this. This is most likely due to the fact that virtual real estate, NFTs and the Metaverse are new technologies, so conventional wisdom would dictate that they abide by new principles. This is far from the truth. The same principles that apply in physical real estate investment also apply in virtual real estate investment.

The market's lack of understanding of how real estate investment works, both physical and virtual, presented the opportunity to invest in virtual real estate and acquire some of the most desirable swathes of LAND within the Metaverse before mass hype and adoption kicked in.

It was clear to me that I needed to take advantage of this opportunity immediately, which is why we set up and launched the Metaverse's first token staking platform to raise capital that could be deployed into, what I believe to be, one of the greatest investment opportunities since the turn of the century. However, upon further investigation, I soon noticed that the majority of Metaverse platforms, and their digital land, was being funded, supported and controlled by most of the same large VC firms. Naturally, this was contributing to the monopolization of the Metaverse, which I believed was not just unfair but also detrimental to its chances of ever realizing its full potential.

I decided that for the greater good of the community, and the Metaverse's best interests, that I wanted to create a protocol that enabled the community to retain as much control over our Metaverseal investments as possible. This desire for decentralization is why vEmpire only took on a few select investors who were happy to invest at the same prices as those who took part in our public sale. This ensured that we only had financial backing from high-quality VC firms that truly believed in our vision such as, AKG Ventures, Oddiyana Ventures, Primeblock and others. Now, less than 3% of vEmpire's total token supply is held privately and this emphasis on solid tokenomics has allowed us to grow tremendously without being labored with overwhelming selling pressure from private investors.

Going back to the "greatest investment opportunity since the turn of the century", since our inception, our investments have appreciated in value between 600-1000%. I always believed that this project would be a surebet, however I have to say that even I've been astonished with how well we've performed.

Over the coming pages you will be introduced to exactly the project that we've evolved into and I have good faith that you too will truly believe in what we are building here at vEmpire DDAO.

Thank you.

- Dominic Ryder, CEO and Founder of vEmpire DDAO

Disclaimer

This document is for general information purposes only. It does not constitute investment advice, recommendation or solicitation to buy or sell any investment, currency or asset stated within this document. This document should also not be used in the evaluation of the merits of making an investment decision. It should not be relied upon for accounting, legal or tax advice or investment recommendation. Instead, this document reflects the current opinions of the authors and is not made on behalf of its affiliates. It also does not necessarily represent the opinions of vEmpire, its affiliates or individuals associated with vEmpire.

The opinions reflected herein are subject to change without notice or being updated.

The reproduction of this document, without prior written consent from vEmpire DDAO Ltd is strictly prohibited.

Contents

Forward	i
Disclaimer	iii
1. Introduction	2
2. Executive Summary	3
3. The Metaverse, Its Problems & The Opportunity	5
4. vEmpire’s Ecosystem of Solutions	7
4.1 The vEmpire DDAO	7
4.2 Staking Strategies	8
4.3 Play-to-Earn Games	8
4.4 P2E Gaming Guilds	9
4.5 NFTs	10
4.6 Metaverse Events	10
4.7 vEmpire Ventures	11
5. vEmpire’s Play-to-Earn Games	12
5.1 vEmpire: “The Beginning”	12
5.1.1 Lore	13
5.2 vEmpire’s Hack ‘n Slash	13
5.3 Wonders of the Ancient World	14
6. Tokenomics	15
6.1 Tokens	15
6.2 Funding	16
7. Marketing Strategies	18
8. The Team	19
9. Roadmap	20
10. Audits, Security & Compliance	21
11. Conclusion	22
12. Acknowledgments	23

Introduction

This document is designed to introduce the reader to vEmpire DDAO, the leading decentralized Metaverse investment organization and inform them about the project's vision, goals and strategies for building the single greatest Metaverse investment ecosystem.

vEmpire's main objective is to lower the barrier to entry for investment in the Metaverse, while also contributing to improving decentralization to ensure that control and influence over "decentralization" projects remains in the hands of the community.

This document will outline the current state of the market, its biggest problems and the trillion dollar opportunity that is the Metaverse. This document will also explain, in great detail, vEmpire's solutions to these problems and how they fit into their ecosystem of products and services offered.

On top of this, the document will also delve into the project's team, tokenomics, funding and marketing strategies to transparently outline essential information that is quite commonly ignored by other "decentralized" projects.

If upon completion of reading this document the reader still has other questions, they can find more resources on our official website, including a condensed version of this document, a link to our documentation and an explainer video that will help with easier digestion of the proceeding information. Alternatively, they can reach out to the team by creating a ticket in our dedicated Discord server if they have any questions that have not already been answered across official vEmpire resources.

On the next page, the reader will find the contents section. Please use this to navigate through to sections of particular interest. For those who are short of time, we have an Executive Summary that provides a concise overview of the most important information within this document. Although this section is intended to provide a concise overview of vEmpire DDAO, we recommend that all first time readers start with this section so that they can first have a broad overview of vEmpire and its ecosystem to avoid confusion in the later sections of this whitepaper.

Thank you for taking the time to read this document,

The vEmpire Team

Executive Summary

The purpose of this paper is to introduce the reader to the Metaverse, its unique opportunities, its greatest risks and finally, how we intend on combating them. We hope that it will provide insight into why we believe the Metaverse to be one of the greatest investment vehicles ever and detail exactly how we intend on capitalizing on it.

We believe that the Metaverse has tremendous potential due to the fact that it can introduce new opportunities and possibilities that will greatly enhance the way that people communicate and interact. However in its current state, the Metaverse still has a lot of room for improvement as there are a multitude of issues that will cripple its prospects of being one of the most influential technologies ever.

vEmpire was formed in an attempt to fight against a collectively centralized Metaverse and to lower the barrier to entry for investment in the Metaverse to make it more equitable, representative and fair. We believe that the Metaverse should remain a decentralized technology that is controlled by the many and not the few and it's our mission to ensure that the Metaverse has investment opportunities that the average investor can access.

To combat the problems later outlined in this paper, we have established an ecosystem of solutions that will help combat centralization while also helping us lower the financial barrier to entry. These products and services will help us to ensure that the Metaverse becomes one of the most influential technologies ever that does not ultimately fall into the wrong hands.

Our staking strategies help us lower the barrier to entry for Metaverse investment by enabling investors to access investment opportunities that would otherwise be out of reach. Not only does this contribute to making the Metaverse more representative and decentralized, but it will also unlock oceans of capital that would otherwise not be available. Our play-to-earn games provide interactive and immersive mediums for interacting with the vEmpire protocol to help keep our community engaged, while also introducing new earning mechanics for our most loyal users to take advantage of. Our Events and Ventures operations will ensure that vEmpire can become one of the most omnipresent brands throughout the Metaverse as they enable us to capitalize on the business-to-business markets. Finally, our Democratic Decentralized Autonomous Organization redefines the way that we facilitate collaboration between like-minded strangers all around the world in the most secure, transparent and economically equitable way possible.

Within the vEmpire ecosystem there are three main tokens. These are the VEMP token, the xVEMP token and the xsVEMP token. The VEMP token is the only token within our ecosystem that is publicly tradable on open markets. VEMP token holders can stake their tokens on our application to receive xVEMP. This is our governance token that earns interest and represents ownership into our DDAO including providing voting rights.

On top of that, all xVEMP holders also receive a share of the profits generated from other vEmpire products. This means that as vEmpire's products, services and investments grow larger and generate more profits, then greater rewards will be distributed equitably between our DDAO stakers. On top of this, the VEMP token can also be exchanged for our xsVEMP token to use in our official play-to-earn games.

The team behind the project is highly experienced and has an extensive background working in the cryptocurrency industry. The project was founded by brothers Dominic and Michael Ryder and has since grown with four additional core team members and over ten developers. When it comes to security, all of vEmpire's smart contracts and sub-economies within the vEmpire ecosystem have been audited by leading third-parties and all valuable assets are stored and managed on Ledger hardware devices.

Conclusively, we believe that our ecosystem combines to make vEmpire the most sound, sophisticated and whole Metaverse investment ecosystem throughout the entire industry.

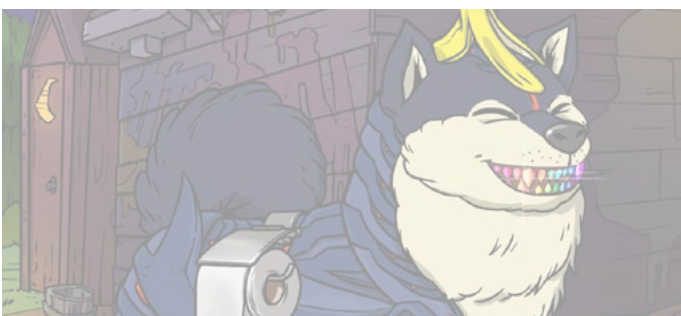
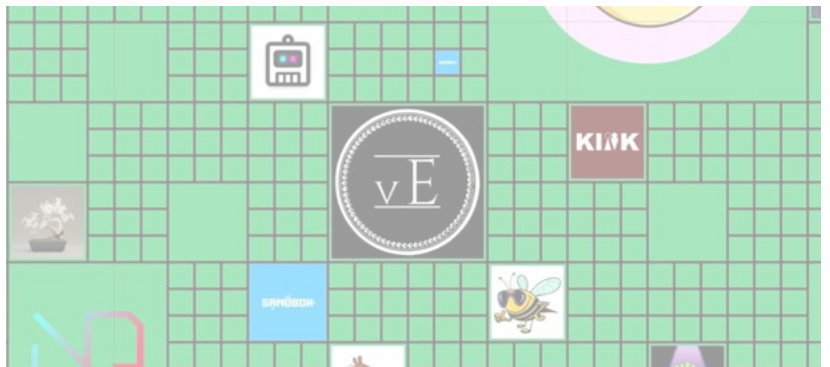
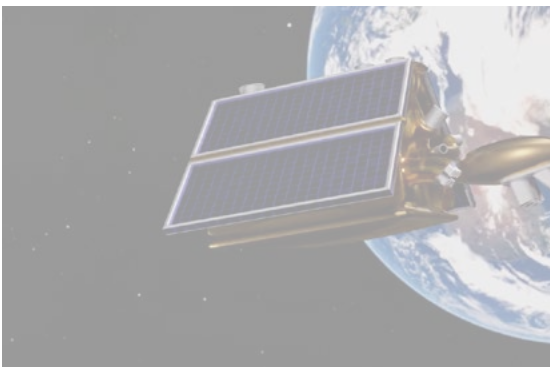
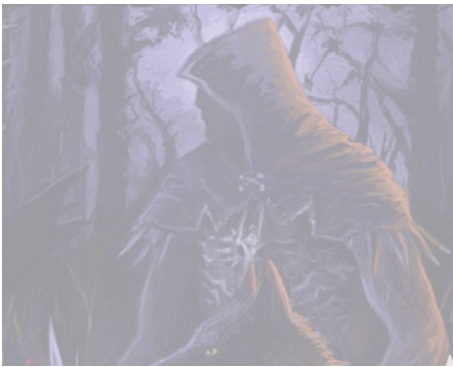

The Metaverse, Its Problems & The Opportunity

The Metaverse is a virtual space that enables individuals to interact with each other in a completely virtual environment. It can be thought of as a collection of virtual realities that exist digitally and that enhance social interaction and collaboration beyond what's possible in the physical world. The Metaverse is very similar compared to the physical world, in the sense that each Metaverse platform has a finite amount of space and that experiences and interactions take place in real time.

To make this entirely new concept easier to understand, let's use an analogy that everyone can understand. The "Metaverse", when spoken about collectively, can be thought of as the planet Earth. Different Metaverse platforms can be thought of as different countries. These different platforms all exist within the "Metaverse", boasting their own virtual real estate, ecosystems and economies, just like countries. While the idea of these virtual worlds might seem trivial at first, the Metaverse is actually the ultimate technology that can help bridge the gap between physical and virtual realities and it will introduce new forms of collaboration, interaction and socialization that transcend what was previously possible in the physical world.

The world is becoming more and more digital. That's an observation that not many would oppose. However until recently, what was unknown was how we could merge the benefits of physical realities with the new and innovative possibilities that modern day technologies now offer. We believe the Metaverse to be this new technology that can bring both the physical and digital worlds together to create a universal reality that exists across multiple realms.

The Metaverse has tremendous potential due to the fact that it can introduce new opportunities and possibilities that will greatly enhance the way that people communicate and interact. Due to the recent breakthroughs of blockchain technology, we can now capture, store and trade value purely electronically in transparent, secure and permissionless ways. It is this breakthrough that has enabled the Metaverse to solidify its promise as a viable bridge between physical and digital realities.

Thanks to this, we can now capture value in the Metaverse and trade this just like we would trade value in the physical world. Now, the same factors that cause the physical world to have value are also present in the Metaverse and with the mass societal shift towards digital living, the Metaverse is poised to capture immense levels of financial value as more and more people choose to interact in it. But it isn't just vEmpire that are completely sold on the Metaverse. While we are still years away from mass adoption and we are one of the earliest adopters in the industry, there are still a select few of other influential figures who also believe in the Metaverse's potential.

Cathie Wood, CEO of Ark Invest has built a reputation for investing in some of the most disruptive technologies ever and she has publicly stated that she believes the Metaverse to be a multi-trillion dollar opportunity. In fact, she also believes that the Metaverse will penetrate into every other major industry around the world. On top of this, Grayscale, one of the worlds largest digital asset managers, and Epic Games CEO Tim Sweeny also believe that the Metaverse will be one of the most lucrative investment opportunities over the coming decades; and Matthew Ball, CEO of the Venture Capital Firm Epyllion, has publicly stated that the value of the Metaverse can one day reach up to \$30 trillion dollars.

Outside of the Web 3 industries though, we also have a lot of more modern technology companies attempting to take advantage of the Metaverse. We've even seen tech giants like Meta, formerly Facebook, throw their hat into the Metaverse mix, even going so far as to rebrand their entire company around the new technology. However in its current state, the Metaverse still has a lot of room for improvement as there are a multitude of issues that will cripple its prospects of being one of the most influential technologies ever.

Anyone who has interacted with any Metaverse protocol whatsoever will know that typical barriers to entry are ludicrously high. This is damaging because it will prevent new money from flowing into the Metaverse as the average user is priced out of entry. However, something that most users will not know is that the Metaverse's largest and most promising protocols are actually funded and run by a small select few organizations. Much like real life, when few entities control or heavily influence entire industries, monopolization is inevitable. We cannot allow this to happen.

Unless something is done about making sure that the Metaverse remains decentralized and the barrier to entry is broken down to allow the "little guys" to access opportunities that would otherwise be out of reach, the Metaverse will never realize its true potential. Not only would this cause an extreme financial loss in opportunity cost, but it would also be a wasted opportunity to further mankind.

This is why vEmpire DDAO exists.

vEmpire's Ecosystem of Solutions

As outlined in the previous section, we are totally committed to lowering the Metaverse's barrier to entry and working to ensure that it remains a decentralized technology. In this section, we will be explaining exactly how we intend on doing this by introducing you to some of the core elements within our ecosystem. Collectively, these products and services make up vEmpire's core offerings to the market.

The vEmpire DDAO

A decentralized autonomous organization, or a DAO for short, is a new type of organization that has no central authority or entity governing its leadership. These new types of organizations are significant because they are effective and safe ways of collaborating with other like-minded actors around the world. However, in their current state, DAOs have many flaws especially when it comes to important factors such as voting power and barriers to entry.

vEmpire is redefining what it means to be a DAO. Our new model for DAOs is a much fairer system that is much more equitable. Instead of focusing on sheer monetary contributions alone, when it comes to ownership and participation, voting power is measured as one vote per wallet above a certain amount. We call this our Democratic Decentralized Autonomous Organization, or DDAO for short. What makes this significant is that it enables us to ensure that everyone within the vEmpire ecosystem has a much more equal and fairer opportunity of voicing their opinions to ensure that as vEmpire and the Metaverse both grow, influence and power can remain representative and equitable.

The vEmpire DDAO presents the unique opportunity for investors to, metaphorically speaking, own the Metaverse's haystack. Instead of attempting to find winning projects themselves, investors can build exposure to an extremely large number of pooled investment opportunities, that leverage other investors' capital, and take a percentage of the profits. When an investor has claim to the DDAO, by owning and staking the VEMP token, they receive exposure to a percentage of vEmpire's total investment portfolio. This means that as vEmpire profits, the DDAO does too. This enables investors that don't have the time, financial or knowledgeable resources to actively invest in the Metaverse themselves to do so passively and with minimal barriers to entry. This will help onboard thousands of new investors and introduce hundreds of millions of new capital to the industry.

On top of receiving an allocation of vEmpire's investment profits, being involved with the vEmpire DDAO also presents many other benefits, including random giveaways, private investment opportunities and access to an extensive network of other Metaverse

investors. Collectively, having exposure to the vEmpire DDAO can be likened to having exposure to the Metaverse's most elite "index fund".

Staking Strategies

Our staking strategies were, at its core, what vEmpire was originally built around. We were, and still are, the world's first protocol to enable Metaverse token staking. These strategies enable investors to commit their funds to specific staking pools that vEmpire can then use to generate profits from within a specific ecosystem. This way, investors can pool together their funds to access investment opportunities that would otherwise be out of reach, benefiting from fractional exposure to a particular protocol's most lucrative opportunities.

On top of this, contributing to our staking strategies also enables investors to earn a dual yield passive income on their holdings, paid in both VEMP and the token originally staked. It's worth noting though that dual yield aggregation is not paid immediately after the launch of a staking pool, instead once the strategy has a mature and liquid investment portfolio.

What makes our staking strategies significant is that investors can now earn passive income and access investment opportunities that would otherwise be out of reach in ecosystems that they're personally most bullish on. This means that our investors can make the decisions themselves on what Metaverse protocols have the most potential and hand over their funds to vEmpire to monetize. This makes earning passive income on Metaverse cryptocurrencies truly passive and provides our investors with another stream of income while they wait for their assets to appreciate.

When a user deposits to a staking pool, there are no fees or minimum lock up requirements. However, when a user wishes to unstake from a chosen pool, they will need to either burn or lock-up 10,000 VEMP for two weeks. This lock-up period can be cut short after one week by burning 50% of the total locked VEMP.

Currently the vEmpire staking platform supports staking for eight different cryptocurrencies. These are; ETH, BNB, SAND, MANA, AXS, STARL, APE and VEMP. Each of these staking pools have their own individual and unique strategy with the user's contributed funds invested within the currency's corresponding native economy. Due to each strategy being totally unique, and new strategies being formed as time goes on, we have decided to leave out the intricacies of each of them in this document. You can however find a more detailed breakdown of all of our staking pool's strategies, including our most recent ones, in our documentation repository on Gitbook.

Play-to-Earn Games

vEmpire is creating an ecosystem of play-to-earn games that will offer unique and immersive gaming experiences while also introducing new financial earning opportunities.

These games will provide the community with opportunities to socialize and and earn at the same time, which will make being involved with the vEmpire ecosystem that much more rewarding. However, we believe that the real advantage of creating this ecosystem of games is that it will enable us to capture, introduce and onboard thousands of new users to the opportunities that the Metaverse has to offer.

Yes, ensuring that our community is entertained and engaged is something that is extremely important to us. However, we believe that introducing a plethora of new users to the Metaverse to be the ultimate benefit of creating our gaming ecosystem as not only will it help vEmpire reach new audiences, but it will also help with the Metaverse's mass adoption rate and governance going forward.

By capturing new audiences, vEmpire can introduce them to the unique investment opportunities that we possess to ensure that more retail investors can be involved with shaping how the Metaverse matures.

This is important because it will help ensure that the Metaverse can be more representative as it grows which will ultimately contribute to it reaching its full potential as one of the most influential technologies ever.

Currently, we have created and launched our own on-platform trading card game titled "vEmpire: The Beginning" and we have another two games under development in The Sandbox. We do have more plans for creating new games in the future, whether that be via the official vEmpire brand or one of our many affiliates.

P2E Gaming Guilds

Monetization across most play-to-earn games is easy once you have the assets required to do so. However something that the majority of investors do not have is the time necessary to grind games to make play-to-earn opportunities worthwhile. However at vEmpire, we have created our own dedicated Gaming Guilds that are made up of avid gamers from all around the world. These guilds are enlisted to play P2E games with vEmpire owned assets that are bought from the funds that are deposited by our investors via our staking strategies. This enables vEmpire to monetize their assets around the clock and distribute these rewards to our pools of investors that provide initial capital by staking their Metaverse tokens on our app.

At the time of launching our Metaverse staking pools, AXS was the only strategy that had a gaming economy diverse enough to actually monetize by playing the game as intended. However now, vEmpire has a guild of just under four-hundred gamers that help monetize our assets twenty-four hours of the day and these individuals are helping vEmpire and our investors monetize assets from a plethora of play-to-earn projects including, Axie Infinity, Aavegotchi, Starl, Star Atlas and World of DeFish.

On top of helping investors monetize their assets, vEmpire also provides gamers from all around the world, who don't have the financial means to acquire blockchain-based

gaming assets, the opportunity to play P2E games and earn from them themselves. Thus, our Guild lowers the barrier to entry for gamers, while also providing investors with the opportunity to monetize their assets passively. This way, everyone's a winner.

Official vEmpire NFTs

NFTs have taken the world by storm and have quickly emerged as one of blockchain technology's most prominent and promising use cases. Although digital art has been one of the biggest use cases for NFTs thus far, there are actually much greater use cases for them. This includes tokens that provide access to exclusive digital content, tokens that represent tangible assets and tokens that make the trading of traditionally illiquid assets more liquid. These new technologies empower creators and have naturally spawned the creation of a new economy where intrinsic value can be accurately measured and securely traded. Naturally, the potential for non-fungible token technology is massive.

It's for these reasons that we've decided to integrate NFT technology into the vEmpire ecosystem to further empower our users and to make our protocol more dynamic. Currently there are two official vEmpire NFT series'. These are "The Founding Soldiers" and "The Plebeian Council". Together, these two NFT series represent and bring our Roman Themed Lore to life. Our Soldiers are used within our trading card game "The Beginning" to provide slight in-game advantages and our Plebeian Council NFTs are used to provide their holders with passive income from the profits generated from "The Beginning".

What these NFTs do is bring yet another layer of immersion and exclusivity to the vEmpire protocol by introducing new mechanics that would not be possible without non-fungible token technology. Instead of just being novel additions to our ecosystem, our NFT products serve crucial purposes that greatly enhance our user experience and accelerate earning opportunities for our investors.

Metaverse Events

As a Metaverse investment ecosystem, it's natural that we would come into ownership of virtual real estate in some of the Metaverse's most promising and lucrative land parcels. In an attempt to monetize this land, vEmpire has enlisted the help of some of the industry's leading architects and virtual real estate developers to create virtual venues that can host a wide variety of events. To date, vEmpire has currently developed five different venues that will soon begin to generate income.

These events will provide the protocol with predictable cash flow once sufficient demand for virtual real estate is introduced. Not only does this benefit vEmpire and its investors, but it will also enable us to run interactive educational events to help onboard younger audiences to the industry in an attempt to capture some of the brightest minds over the coming years. This will help vEmpire become an omnipresent brand during the Metaverse's maturation phase. This is significant because it will cement vEmpire's place as one of the leading Metaverse ecosystems while also providing financial benefits to its supporters.

vEmpire Ventures

To help with the widespread adoption and successful maturation of decentralized play-to-earn gaming and Metaverse protocols, we've created Venture funds and a small scale incubator to help promising projects successfully bring their products to the market. Not only will these funds provide the vEmpire protocol, our investors and our institutional partners with potentially extremely lucrative returns on investment, but they will also enable vEmpire to direct and shape the way in which some of the Metaverse's highest potential projects are built. By doing this, we can ensure that the community is front and center of all of the early-staged projects that we work with. This is significant because it will ensure that promising projects are not lumbered with the burdens that typical Venture Capital firms bring, but instead financially backed and supported by a loyal community of investors that want to see the most promising projects thrive in the long term.

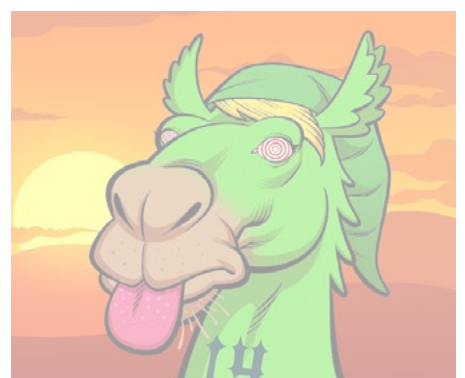
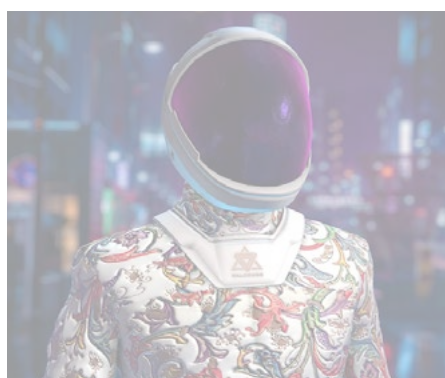
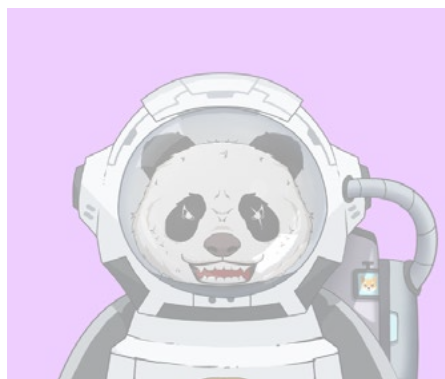
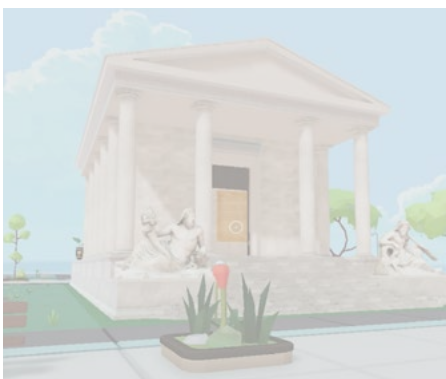
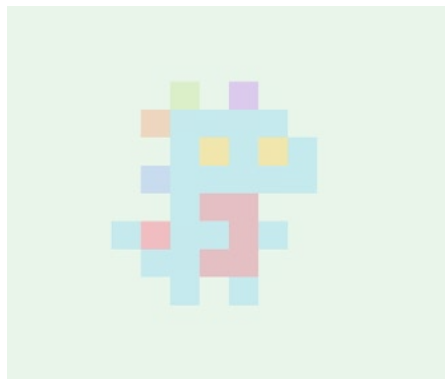
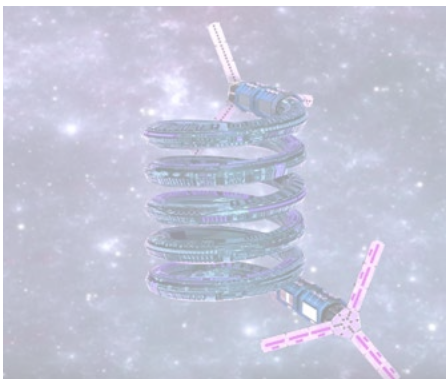

vEmpire's Play-to-Earn Games

In one of the previous subsections, we highlighted the significance of our play-to-earn games and how they will contribute to making the protocol more engaging and immersive and how they will introduce new earning mechanics for our community. In this section, we want to outline exactly what progress has been made and introduce you to the unique facets of our three unique P2E games that have either been released or are still under development.

vEmpire: "The Beginning"

In Q1 of 2022 we released the full play-to-earn version of our first ever gaming release, vEmpire: "The Beginning". This came a few months after releasing the free version back in November. After trialing the free-to-play version for a few months, we were able to get some insightful feedback from our core community to iron out the bugs and make some final amendments before full market launch.

Up until recently however, the only playable version of "The Beginning" was our full play-to-earn version. Since then, we've decided to release the free-to-play version once more to help new players get to grips with the mechanics and to introduce and onboard new players to the game before expecting them to actually risk their funds. This lower barrier to entry will enable more gamers to be exposed to "The Beginning" in more organic ways, thus helping with increasing our user base and improving player retention rates.

The structure and mechanics of "The Beginning" is very simple. Upon launching the game, users can either create a new room or join an existing one to be immediately partnered with another player. The users then select which faction they would like to play as and how much xsVEMP (more on that in our Tokenomics section) they would like to contribute to the prize pool. After this, the users select the risk level, either 10%, 20% or 50%, which will determine how much of the total xsVEMP from the prize pool can be won. The mechanics on how the game is actually played can be found in our game manual.

Upon completion of a game, the winning player will take the winnings from the prize pool, minus a 10% fee. This small fee is distributed to different destinations, with 25% going to Plebeian Council NFT stakers and the remaining 75% going to the DDAO.

In order to verify and test the quality of our game economy, we enlisted audits from a third party to review and test the balance of our economic systems. We're pleased to say that our game economy was deemed fair and balanced, with no particular advantage to either faction above the other. The findings from this audit can be found in our Audits, Security & Compliance section.

“The Beginning” plays an important role within the vEmpire ecosystem. On top of being a fun, strategic game that provides earning opportunities for our community, the game also serves a crucial purpose within vEmpires economy. Going forward, we will be looking to build on this, adding more cards and even new factions to expand and improve the game to make it more rewarding for our community.

The Beginning’s Lore

After years of quietly building military strength, the time has come for the Empire to expand its borders and seek out a new place to rule. The Empire has set its sights on the Metaverse and by using efficient military training that’s been honed over time, the Empire will soon conquer and absorb everything in its path.

However, all is not unified contrary to how it may seem. After the peaceful reign of the former Emperor, his two sons vie for leadership. Romulus and Remus never saw eye-to-eye and each brother will not let the other get in their way of unlimited power.

Romulus is a strong leader of men, who wins the hearts of his people with responsibility and promises of power and wealth.

Remus is the true son of the wolf. He is sly and conniving and uses strategic tactics efficiently in battle. He may not be as popular as Romulus, but he will not be bested easily when it comes to playing the long game.

Within the Empire’s civil war, each brother has at his disposal an army with troops who have unique abilities. After picking a side, players can choose which soldiers to command across different scenarios to counter any advantage that the opponent might think that they have.

Choose a faction and back either Romulus or Remus to the end, helping cement their rightful place as the new Emperor. Train your army and invest your time to build an unstoppable force to take what rightfully belongs to you.

Players can take the all out attack approach and throw their strongest troops at their opponent to win through brute force. Or they can be cunning and outplay their opponent by strategically removing their key players and calling for reinforcements to out number the opposition on the battlefield.

Only when you see your colors flown as high as the eye can see will the conquest be won.

vEmpire’s Hack ‘n Slash

Our Hack ‘n Slash game is the first of our games that has been built and is ready for the release of The Sandbox’s metaverse. Built on one of our first LAND parcels, gamers will be able to immerse themselves in our take of Ancient Rome and visit iconic locations

like traditional Roman Markets, Palaces and even Colosseums where they can battle legendary gladiators! As part of this game development, we've introduced a plethora of different quests and activities that gamers can partake in, including battles, defending locations from bandits and even tending to crops.

Seven Wonders of the Ancient World

Our Seven Wonders of the Ancient World is our largest Metaverse development project by far, being developed on our huge 6x6 plot in The Sandbox. We have restored these long forgotten landmarks from ancient history to their former glory, and gamers can expect plenty of play-to-earn activities to keep them busy at each site! We're nearing completion on these now and we hope to be able to provide our community with another update in the near future.

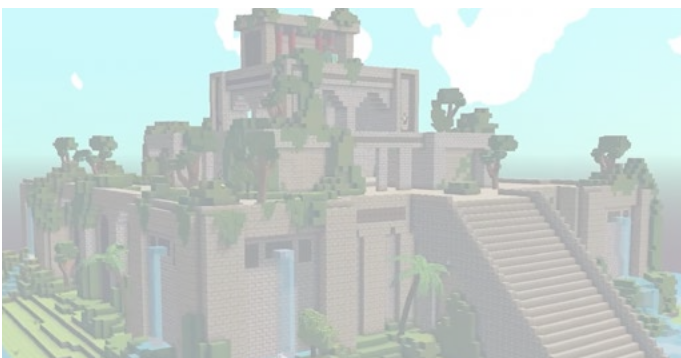

Tokenomics

VEMP, xVEMP & xsVEMP

One of the most integral aspects of our ecosystem is the tokens that make up our economy. The main token within our ecosystem is the vEmpire Gamer Token, or the VEMP token for short. This token is used to reward our stakers and to enter the vast ecosystem of products and services that we have to offer as its exchangeable for our secondary and tertiary tokens that are not tradable on open markets.

VEMP token holders can stake their tokens on our application to receive xVEMP. This is our governance token that earns interest and represents ownership into our DDAO including providing voting rights. Unlike regular decentralized autonomous organizations, we do not base the weight of votes on the numerical size of a user's holdings. Instead, everyone who holds over 10,000 xVEMP carries the same voting power. This way, larger holders do not have the opportunity to influence group decisions in their favor and we can maintain a much more balanced, fair and equitable power distribution.

On top of that, as previously mentioned, all xVEMP holders also receive a share of the profits generated from other vEmpire products. This means that as vEmpire's products, services and investments grow larger and generate more profits, then greater rewards will be distributed equitably between our DDAO stakers. xVEMP holders also qualify for bonus rewards, including NFTs and other Metaverse based asset giveaways.

What's more, when VEMP rewards are sent to the DDAO it raises the price of xVEMP in relation to the price of VEMP. When a user harvests their VEMP (unstakes from the DDAO), they multiply their xVEMP amount by the new higher value. This means that when rewards are harvested, those who've spent the most amount of time staked will receive the most rewards. This helps us incentivize loyalty and will help stabilize the price of VEMP as more supply becomes illiquid.

When it comes to our play-to-earn games, xsVEMP is the battle token that is required to interact with these platforms. When a user navigates to our game, there will be an option to exchange their VEMP for an equal amount of xsVEMP. Although this transaction happens on chain, xsVEMP is not tradable on exchanges and can only be transferred on official vEmpire gaming platforms.

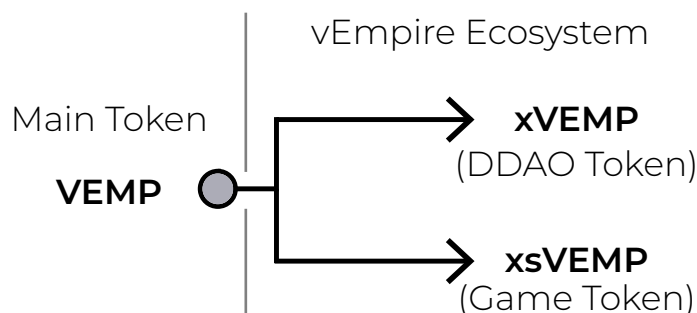

VEMP's Tokenomics, Fundraising & Vesting

When we started vEmpire, something that was of utmost importance to us was ensuring that one of our key assets, our main token, had economically sound tokenomics. This was of particular importance to us because without sound economical principles we would be risking financial suicide which could have potentially catastrophic repercussions. Because of this, we made sure that we had one of the best tokenomics models out of all projects within the Metaverse sector.

The VEMP token has a total fixed supply of 810,720,000. Roughly only 22% of these tokens will ever be in the hands of the team, advisors and private investors. This means that over 78% of VEMPs token allocation will be owned by the vEmpire community.

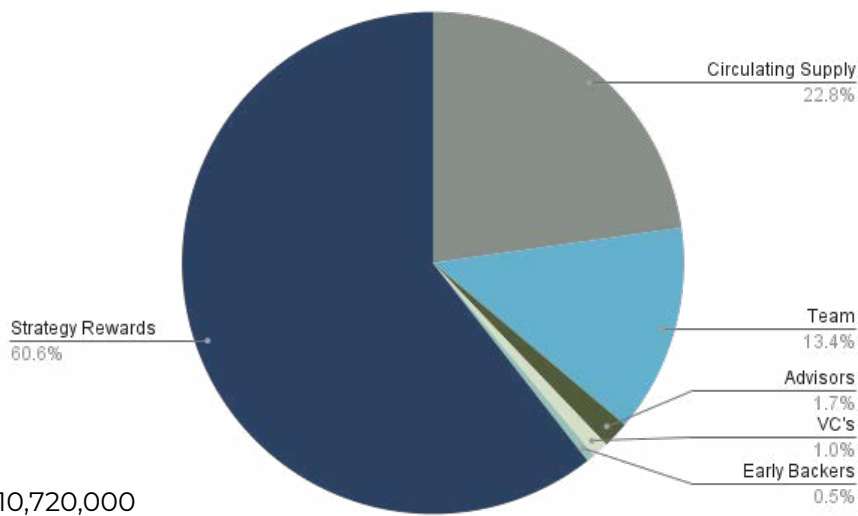

Our monetary policy, which is of particular importance because it defines important economic principles such as supply and demand, is deflationary. This means that over time no more VEMP can ever be minted into existence and that VEMP should theoretically decrease in supply as time goes on. We have done this by ensuring that when a user wants to unstake from one of our Metaverse staking pools they will either have to lock-up 10,000 VEMP for two weeks or burn 10,000 upfront. This will either contribute to a lesser liquid supply of VEMP in the short term or a perminally decreased supply of VEMP in the long term.

The team's token allocation will unlock linearly and this will be over the course of up to 21 years depending on allocation.

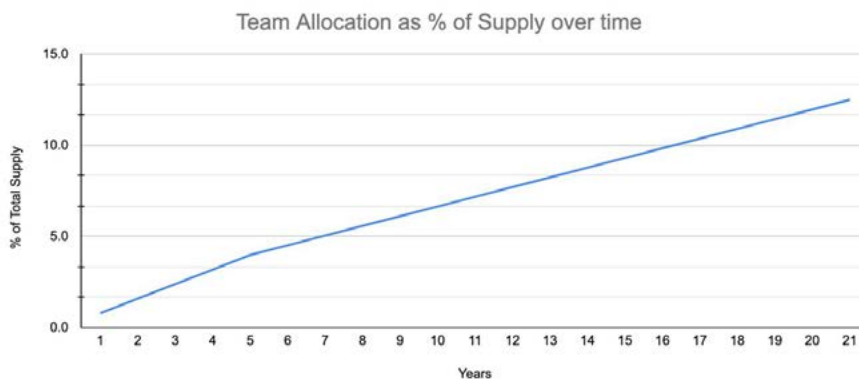

When it came to private fundraising, we attempted to keep as much control as possible within our community. This is why we only accepted investment from a select few Venture Capital firms who were happy to match our public token launch price of 125,000 VEMP per ETH. This means that at the time of launch, our token was worth \$0.027. As our private investors invested at levels identical to the public, it ensured that there wouldn't be an inequitable selling pressure.

We sold just 1.8% of our total supply to Venture Capital firms which has vested linearly for between 6-18 months. This means that at the time of writing (May 2022) only two of these six firms still have active lock-up periods.

VEMP Purchased	Investors	Price of 125K VEMP per ETH at time	All commenced 01/09/2022	Time remaining as at 20/05/2022	% Vested So far
800,000	Oddiyana Ventures	0.025	Linear 12 months	3 months 12 days	71.50%
1,000,000	LucidBlue Ventures	0.025	Linear 6 months	Fully Vested	100%
2,400,000	AKG Ventures	0.025	Linear 12 months	3 months 12 days	71.50%
2,400,000	Coins Group	0.025	Linear 12 months	3 months 12 days	71.50%
4,000,000	Danny Christ Ventures	0.024	Linear 18 months	9 months 12 days	47.67%
5,000,000	Primeblock Ventures (MEXC)	0.02	Linear 18 months	9 months 12 days	47.67%
Total:		Average	Average	Average	Average
15,600,000		0.024	13 months	4 months, 3 weeks	68.31%

Alongside this, an additional 5,000,000 tokens were allocated to early backers of the project and 1.9% of the total supply were allocated to advisors vesting over a period of 24 months.

Marketing Strategies

Our marketing strategy is simple. Our goal is to focus on reaching crypto-natives as we believe that they will be the easiest audience to introduce into the vEmpire ecosystem. We'll do this by rolling out various marketing campaigns, with tactics that will involve organic community participation, key opinion leader collaboration, brand-to-brand leveraging and strategic partnerships with similar projects.

As we're currently operating in an extremely raw market, it's difficult to stand out when a new project with immense hype appears every week. Because of this, we're opting to take the slow and steady approach to building our brand in a simple yet effective way. We believe that this will yield the most results in the long term, which will help us build something sustainable.

The backbone of all marketing strategies is the story and messaging. We've been actively trying to simplify what our project is all about so that it's easier for new investors to understand. We believe that this will create less friction when it comes to onboarding new users, thus contributing to growing the protocol effectively. On top of that, we're also looking to educate new markets around the opportunities presented by the Metaverse in an attempt to morph vEmpire into an omnipresent brand throughout the Metaverse's maturation phase.

When it comes to execution, we will be looking to distribute our message across various channels of communication including, well established Metaverse-focused communities, influencers, brand advocacy and strategic partnerships. We're also working on creating a brand new website to make it easier for visitors to understand exactly what we do and what we stand for. Our staking platform, play-to-earn games and NFT websites will all be revamped and we will even be creating a knowledge base, with the help from our community moderators, to make it easier for our community to find solutions to their problems without having to ask for help.

Finally, we're also currently developing an internal KPI management system that will help us accurately determine whether our efforts are yielding results or not. Once this has been put into place, we will be able to refine and optimize our growth strategies and focus directly on what performs the best for us.

The Team

At the time of writing, the official team is made up of six individuals. These individuals can be split up into two categories. These categories are “Founders” and “Core Team Members”.

The two founders are brothers Dominic and Michael Ryder. Dominic serves as Chief Executive Officer and Michael as Chief Operating Officer. Together they have a combined five years of experience within the Web 3.0 industries. Dominic comes from a stockbroking background as a former partner at St James’ Place in London and Michael has a wealth of experience from within the audiovisual industry having designed and programmed interactive solutions for high profile clients such as ...

From within the “Core Team”, vEmpire is lucky enough to have another four team members that together have a combined nine years experience operating in the cryptocurrency industry. Estefano Ramirez serves as Chief Marketing Officer and has an extensive background in both B2B and D2C marketing, having previously worked with well-known brands such as Microsoft, IBM, Redhat, Cisco, Unilever and many more. Jack Dolby serves as vEmpire’s Venture Lead and has experience running his own NFT marketing agency and working for some of the leading companies within the Web 3 industries, including IOHK, a Polkadot Parachain and many others. Harvey Woods serves as Marketing & Operations Manager and has experience in design, branding and social advertising having previously worked in a creative marketing agency running successful campaigns for large insurance companies, global sweet brands and international charities. Finally, Petar Gavrilov serves as the DDAO Engagement Lead and has experience managing customer service divisions for some of the largest cryptocurrency organizations, including Crypto.com.

Together the team have had over a decade’s worth of experience navigating the cryptocurrency industry. Partnered with their individual beliefs that the Metaverse is the single greatest technological opportunity since the invention of the internet, their wealth of experience and individual expertise will help catapult vEmpire to extreme heights to ensure that the project becomes the largest Metaverse investment ecosystem throughout the entire industry.

Road Map

2022 Q3

2022 Q4

2023 Q1

2023 Q2

2022 Q3	2022 Q4	2023 Q1	2023 Q2
Stable coin pool (token decided by community)	All NFT trading cards listed	Improved UX/UI on vEmpire: The Beginning	Start institutional investment pools
Roll out community voting mechanism	Re-lock 50% of our Uniswap liquidity & increase liquidity pool sizes on other chains	Reassess token burning lock amount	Host first paid Metaverse event
SOL staking pool	Incentivise LP provision	Launch first vEmpire Ventures IDO	Update Website Design

Audits, Security & Compliance

Security is not something that is taken lightly at vEmpire. As we're an investment organization that handles other user's funds, we ensure that the utmost diligence is used when it comes to dealing with the management and storage of valuable assets and data. In this section, we will be breaking down the safety precautions that we take, including what third party audits that we've undergone to verify the authenticity of the project.

Firstly, we would like to point out that all of our smart contracts have been audited. These audits have all been completed by third parties and are publicly viewable on our Github repository. vEmpire have used SolidProof, who're one of the industry's leading smart contract auditors to verify our contracts.

On top of our smart contracts, our game economy for vEmpire: "The Beginning" has also undergone third party testing by the leading game economy auditor Machinations. We're pleased to inform you that we've received their Seal of Approval to verify that our game economy is fair and balanced. The official report on our game economy can be found on the Machinations website.

Finally, when it comes to asset protection, vEmpire stores all valuable assets, that are compatible, on Ledger devices. This precaution ensures that vEmpire's and their user's assets are stored offline and in the most secure way possible to minimize the potential for fraudulent or malicious activity. These devices are some of the most secure on the market and they include tamper-resistant Common Criteria (CC) EAL5+ certified Secure Element (SE) chips to minimize the risk of losing private keys.



Conclusion

The purpose of this paper was to introduce the reader to the Metaverse, its unique opportunities, its greatest risks and finally, how we intend on combating them. On top of that, we also wanted to explain to the reader why we believe the Metaverse to be one of the greatest investment vehicles ever and detail exactly how we intend on capitalizing on it.

Throughout this paper, we believe that we have covered all of these points sufficiently and in necessary detail. We would however like to finish by saying that while we understand that our ecosystem of solutions will undoubtedly require continuous improvement and innovation, we truly believe that our current offering of products and services presents adequate, genuine and unique answers that will ensure that the Metaverse can reach its full potential and that the vEmpire protocol and its most important stakeholders can profit accordingly.

Our staking strategies help us lower the barrier to entry for Metaverse investment by enabling investors to access investment opportunities that would otherwise be out of reach. Not only does this contribute to making the Metaverse more representative and decentralized, but it will also unlock oceans of capital that would otherwise not be available. Our play-to-earn games provide interactive and immersive mediums for interacting with the vEmpire protocol to help keep our community engaged, while also introducing new earning mechanics for our most loyal users to take advantage of. Our Events and Ventures operations will ensure that vEmpire can become one of the most omnipresent brands throughout the Metaverse as they enable us to capitalize on the business-to-business markets. Finally, our Democratic Decentralized Autonomous Organization redefines the way that we facilitate collaboration between like-minded strangers all around the world in the most secure, transparent and economically equitable way possible.

Together, we believe that our ecosystem combines to make vEmpire the most sound, sophisticated and whole Metaverse investment ecosystem throughout the entire industry. We will continue raising the bar, setting higher standards and contributing to Metaverse's widespread growth and adoption.

Thank you for taking the time to read this document.

The vEmpire Team

Acknowledgements

vEmpire would like to extend their thanks to the collaborators of this document. A special thanks goes out to Dominic and Michael Ryder for creating the original whitepaper, Jack Dolby who wrote this updated version of the whitepaper and Harvey Woods, Estefano Ramirez and Petar Gavrilov who contributed to the design, concepts and key ideas behind the material covered in this document. No contribution goes unnoticed.

We would also like to extend a heartfelt thanks to our great community who have believed in us and have helped us develop what vEmpire is today.

vEmpire DDAO would also like to thank its early supporters, including Oddiyana Ventures, LucidBlue Ventures, AKG Ventures, Coins Group, Danny Christ Ventures, Primeblock Ventures and all of the other contributors and supporters who've not been individually mentioned. Without their early support, vEmpire would not be the project that it is today.

Finally, a special mention deserves to go out to our founders Dominic and Michael Ryder who've managed to turn their vision into a reality. Without these two pioneers we would have one less entity fighting for the success, growth and adoption of the Metaverse.